

## Sequential and Combination Timer TK-415

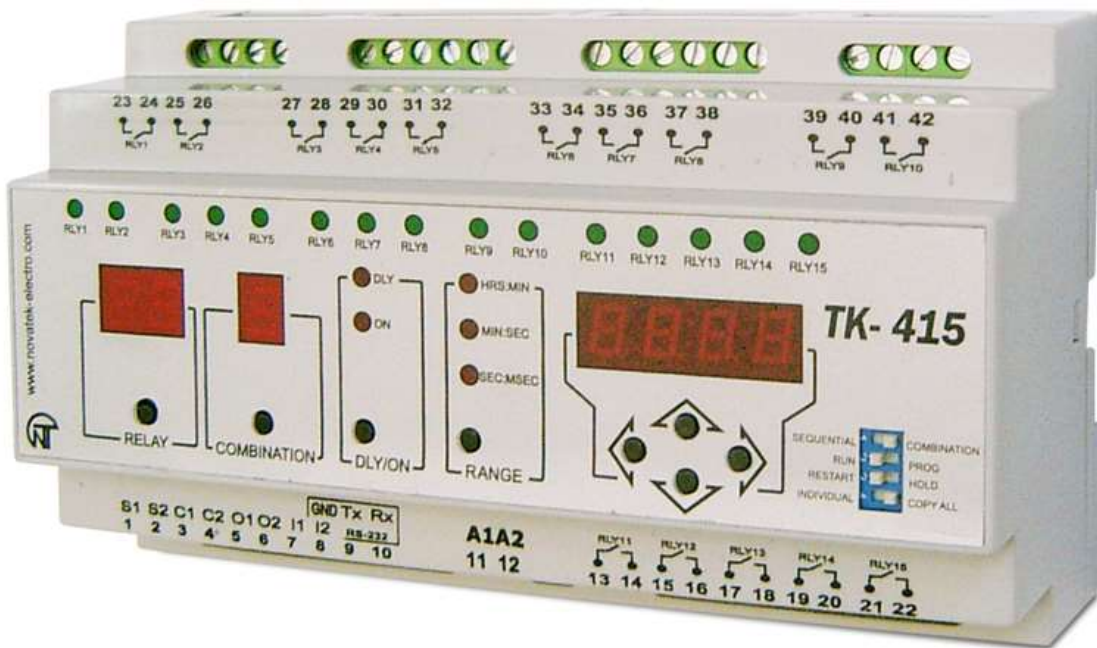

## OPERATING MANUAL

*Quality control system on the production complies with requirements ISO 9001:2008*

Review the Operating manual before using the unit

UKRAINE, Odessa

[www.novatek-electro.com](http://www.novatek-electro.com)

## CONTENTS

1	General provisions .....	2
1.1	Basic functions .....	3
1.2	Basic technical brief .....	2
1.3	External view and dimensions .....	4
1.4	Time diagrams .....	6
2	Setting and operation .....	10
2.1	Connection .....	10
2.2	Safety measures .....	11
2.3	Timer programming .....	12
2.3.1	Sequential timer programmer .....	12
2.3.2	Combination timer programmer .....	12
2.4	Timer start .....	12
2.5	Resetting .....	13
2.6	Settings copying .....	13
2.7	Pause .....	13
2.8	Cycle operation of timer .....	13
2.9	Join operation of several timers in sequential mode .....	13
3	Term of service and storage, manufacturer's warranty .....	13
4	Acceptance certificate .....	14
5	Notices of claims .....	14

**WARNING!**

To prevent the risk of fire or electric shock, avoid falling into the water and the unit of the device under conditions of high humidity.

The unit contains high voltage components, so do not attempt to open and repair the device.

When moving from a cold to a warm location or, conversely, the details of the device can cause condensation that can cause undesired operation. In this case, before connecting the device to the mains keep it within two hours of operating conditions.

Never use abrasive materials or organic substances (alcohol, gasoline, solvents, etc.) to clean the device. Subject to the rules of operation of the device is safe to use.

**1 GENERAL PROVISIONS**

**1.1 BASIC FUNCTIONS**

- microprocessor controlled.
- simple change-over between sequential and combination timer.
- 7-segment LED indications.
- cascade connection of several devices for extended total number of channels.
- memorization of device mode after switching off and program operation restart from breakage.
- inputs for timer start and pause control.
- fast resetting.
- copy of settings.
- program can be executed only one time or/and cyclic operation possible.

**1.2 BASIC TECHNICAL BRIEF**

**Table 1.1**

Supply voltage, V	from 85 to 270 AC/DC		
Frequency range, Hz	47-63		
Power consumption, VA	8		
Time setting range	from 100ms to 99hr59min		
Commutation accuracy	±0.1% + 20ms		
Number of channels	15		
Number of combinations per channel (ON/OFF)	8		
Operating temperature range, °C	from -25 through +55		
Storage temperature, °C	from -35 through +80		
Humidity (non condensing)	95% @ 40°C		
Insulation resistance	>100MΩ @ 500V DC		
Dimensions, mm	85.8 x 156.2 x 56.8		
Indication of load relay	Yes		
Protection level	IP20		
Climatic resistance version	NF4		
Data memory, years, minimum	10		
Output Relays, CO	15		
Channel contacts type	normally open contact (NO)		
<b>Characteristics of output channels</b>			
<b>cos φ</b>	<b>Maximum current at U~250V</b>	<b>Maximum capacity</b>	<b>Maximum current at Uconst=24V</b>
1.0	10 A	2500 VA	10 A
0.4	4 A	1000 VA	
Commutation resource of output contacts:			
- mechanical resource			10 <sup>7</sup>
- electric resource 10A 250V AC, times, minimum			100 000
- electric resource 10A 24V DC, times, minimum			30 000
- electric resource 4A 250V AC (cos φ = 0,4 ), times, minimum			100 000

Signal «Start»	Contact Closure S1 and S2 maximum at 150 milliseconds
Mounting	onto standard 35 mm DIN-rail
Mounting position	any

### 1.3 EXTERNAL VIEW AND DIMENSIONS

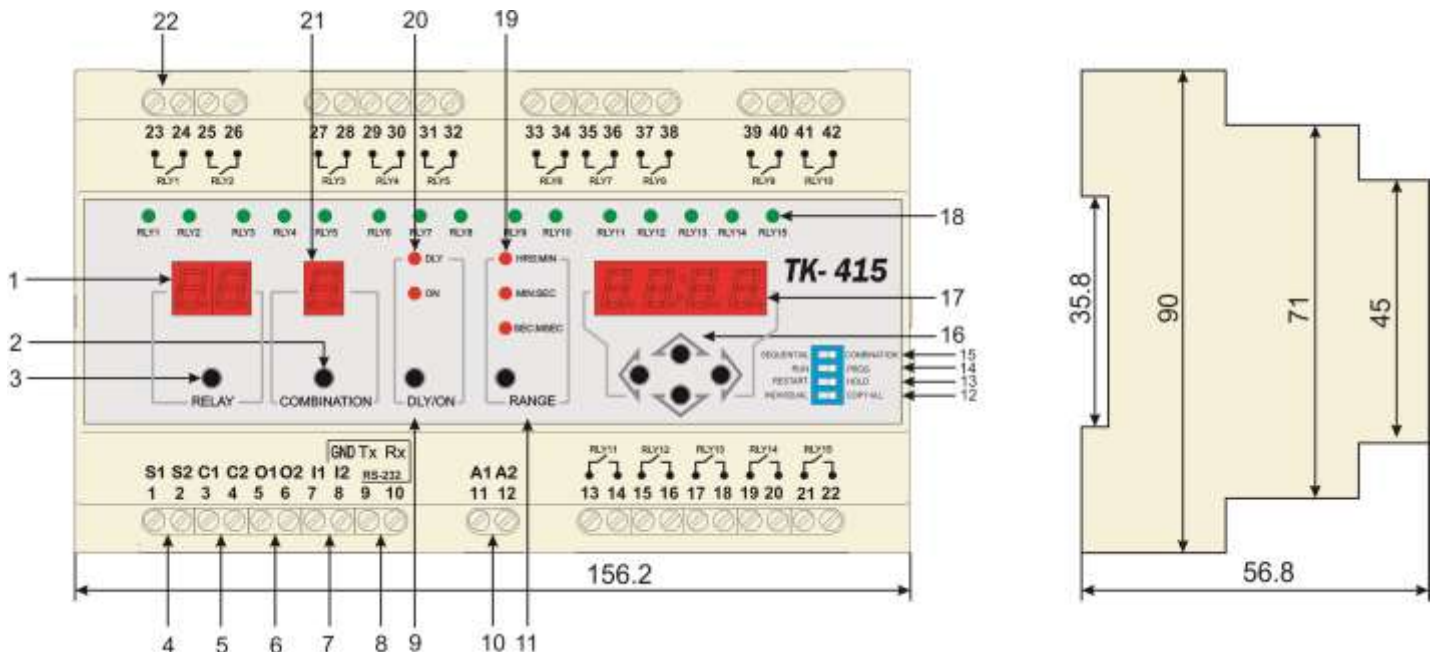

Figure 1.1

1. Indicator for selected channel.

**2. COMBINATION**

Button of selection of combination DLY/ON of active channel in case of timer operation in combination mode.

**3. RELAY**

Button of selection of channel for programming or channel information displaying.

**4. S1/S2**

Inputs of timer start for program execution. For start of program processing inputs S1 and S2 should be closed for 150 milliseconds. Switch RUN/PROG should be in position RUN.

**5. C1/C2**

Inputs of looping execution of program. If inputs C1 and C2 are closed, the program is executed only one time. Otherwise, the program would be in cyclic mode.

**6. O1/O2**

Outputs of cascade connections of devices. After completion of execution of program outputs O1 and O2 are closed for 200 milliseconds.

**7. I1/I2**

Inputs of pause control. Zero potential between I1 and I2 suspends the program execution. After unshorting between I1 and I2, the execution of program is continued from the suspension time.

**8. RS-232**

COM port for copy options from personal computer. See [novatek-electro.com](http://novatek-electro.com) for software.

**9. DLY/ON**

Button of selection of time setting of open (DLY) or closed (ON) contacts of active channel output.

**10. A1/A2**

Power inputs according to technical specifications.

**11. RANGE**

Button for selection of range of time programming DLY/ON according to the Table 1.2:

**Table 1.2**

Designation	Range
HRS:MIN	from 1 minute to 99 hours 59 minutes
MIN:SEC	from 1 second to 99 minutes 59 seconds
SEC:MSEC	from 100 millisecond to 999.9 seconds

**12. INDIVID/COPY ALL**

When the switch is in position INDIVID, the program will be executed for every channel independently as it have programmed. If switch is in position COPY, during execution of the program the values of times DLY and ON for every channel will be used from first channel.

**13. RESTR/HOLD**

Selection of device behavior in case of absence of external power. If the switch is in position RESTR, the program will restart from the very beginning after restoration of power supply. If it is in position HOLD, the timer settings at the moment of emergency switching will be stored in nonvolatile memory and the program will be restarted after restoration of power supply.

**14. RUN/PROG**

The selection of PROGRAM or RUN timer mode.

**15. SEQ/COMB**

Selection of timer principle of operation: sequential or combination.

**16.** Buttons for selection of position and setting of values on Time indicator 16.

**17.** Time Indicator.

**18.** Indicator displaying closed/open mode of channel contacts.

**19.** Indicator of selected time range (see Table1.2).

**20.** Indicator displaying current mode of time programming of open (DLY) or closed (ON) contacts on Time indicator.

**21.** Indicator of selected combination for combination timer.

**22.** Terminals for load connection to output channel contacts.

**1.4 TIME DIAGRAMS**

I. Sequential timer, mode of execution of one cycle of program (inputs C1 and C2 are shorted):

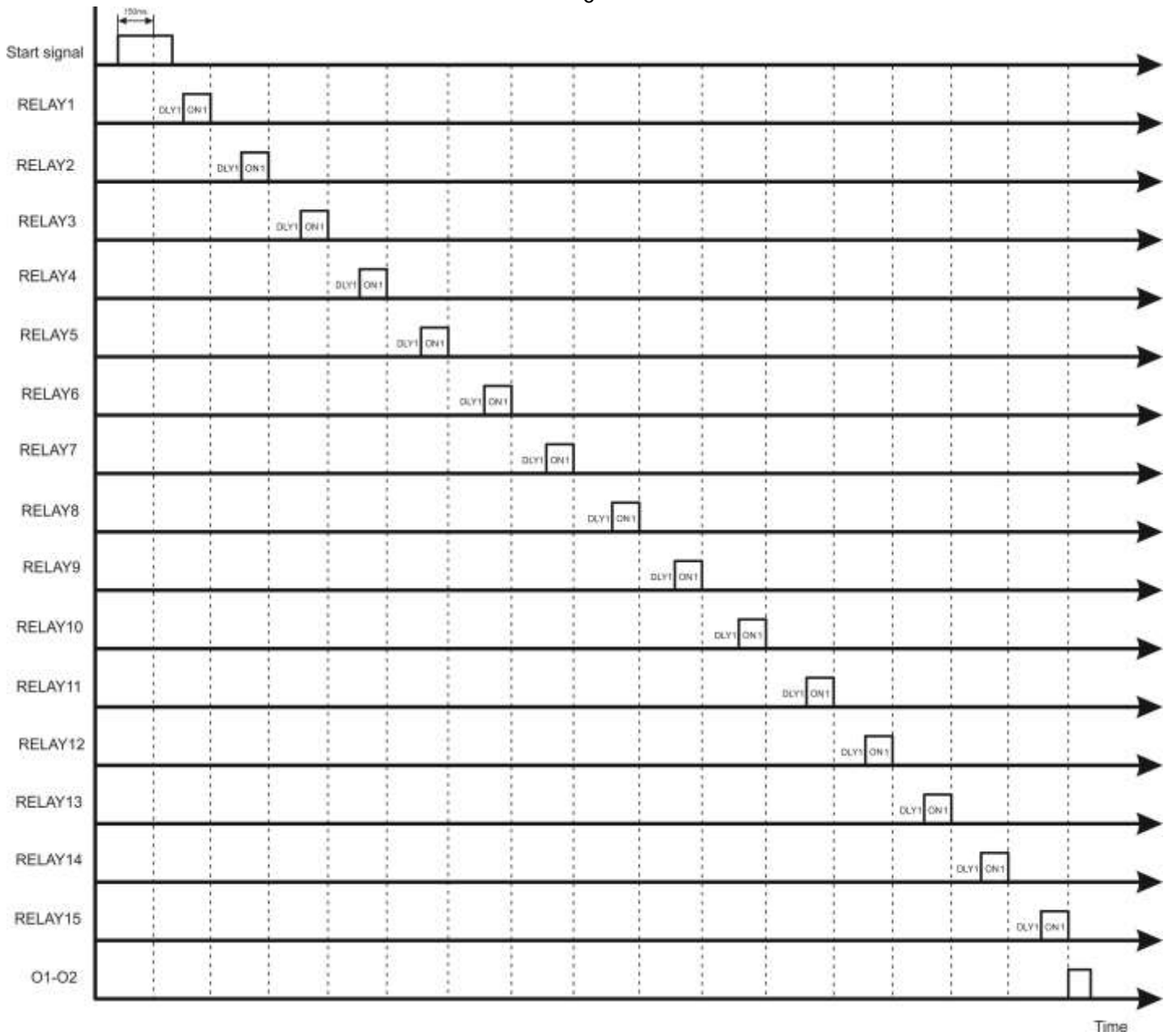

Diagram 1.1

II. Sequential timer, cycling mode (inputs C1 and C2 are not shorted):

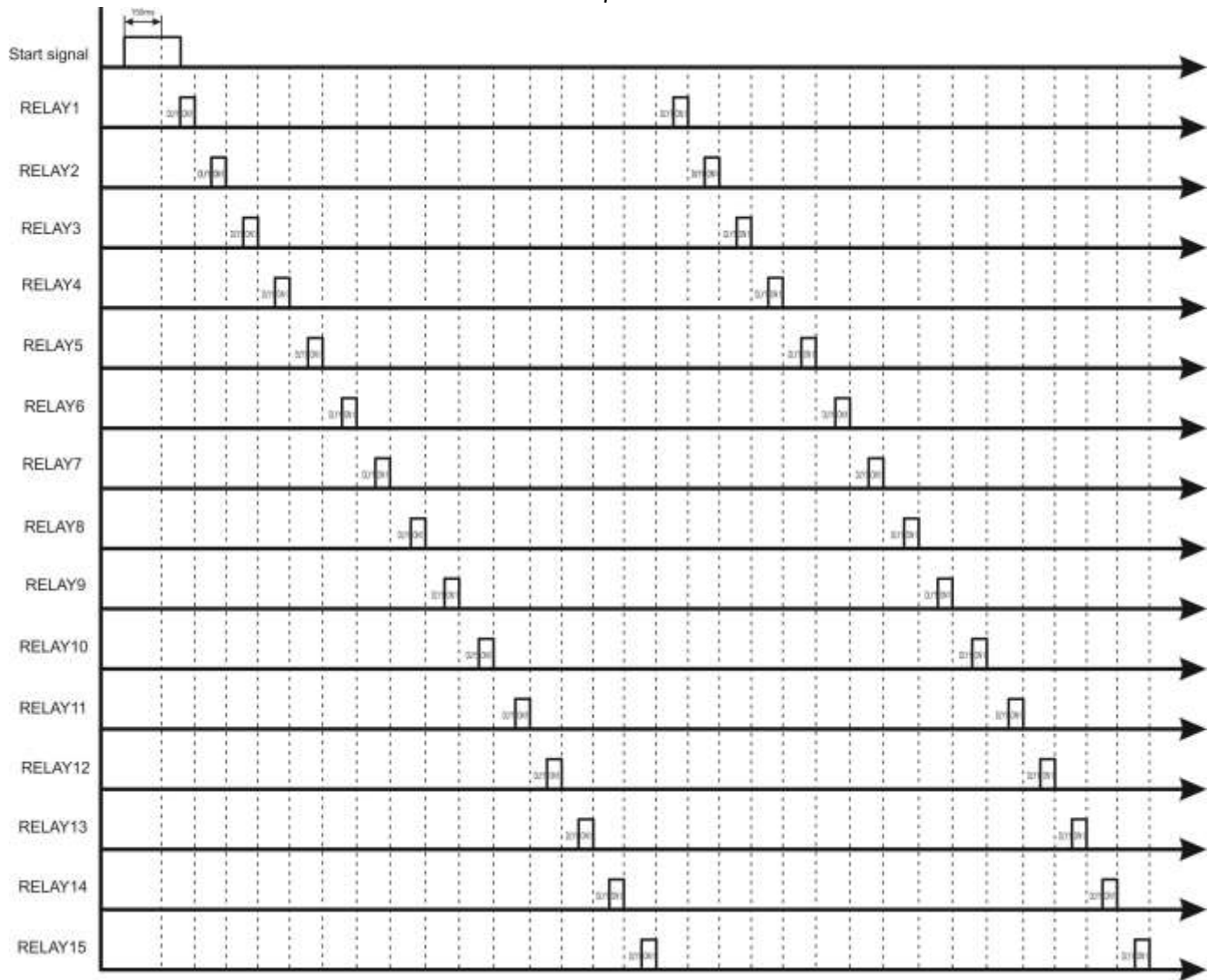
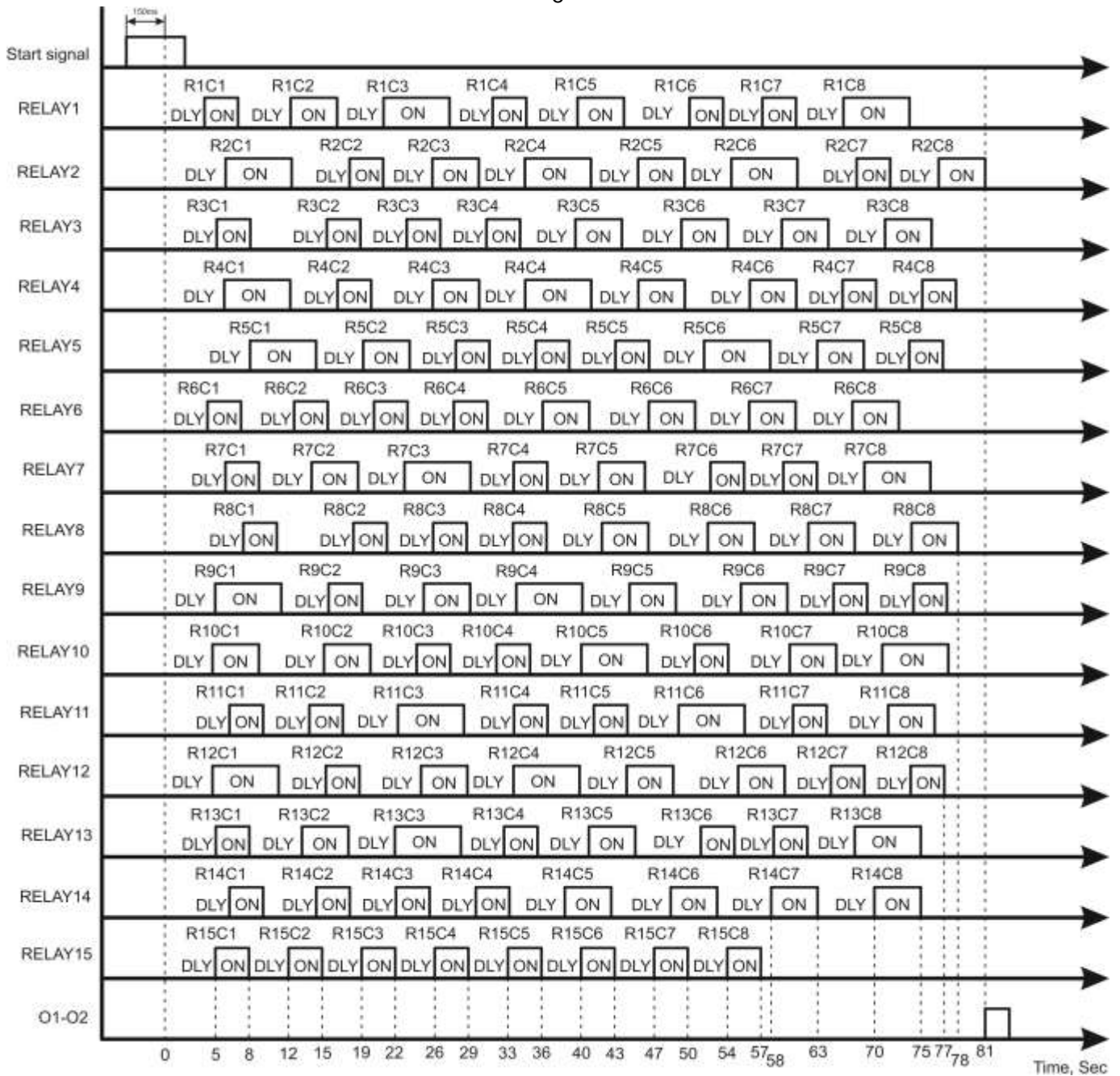

Diagram 1.2

III. Combination timer, mode of execution of one cycle of program (inputs C1 and C2 are shorted):



**Diagram 1.3**

Where, for example, R2C5 means the fifth combination of the second channel (relay).

IV. Combination timer, cycle mode (inputs C1 and C2 are not shorted):



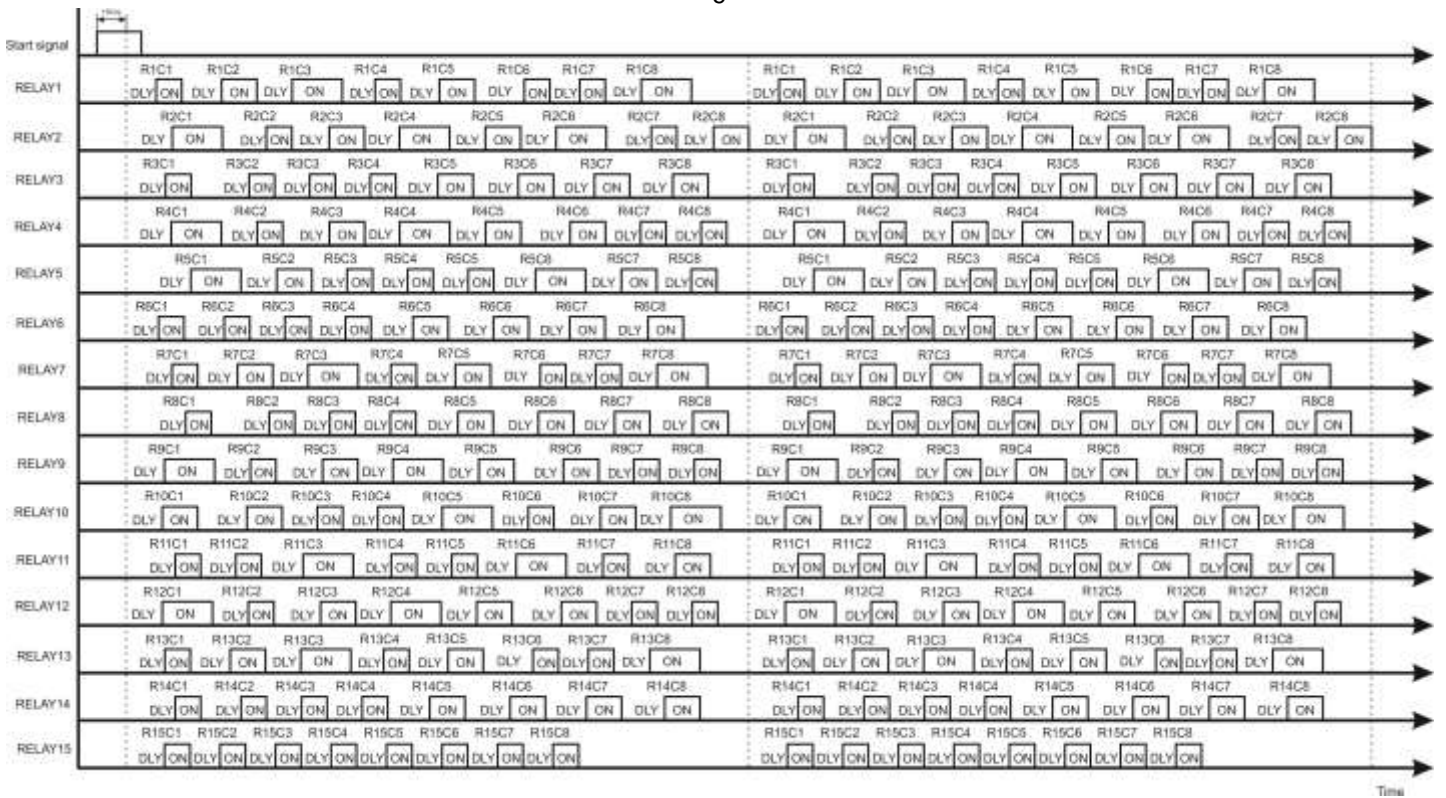

Diagram 1.4

## 2 SETTING AND OPERATION

### 2.1 CONNECTION

The Figure 2.1 represents the typical method of timer connection. Load is connected to output of channel RLY10 as an example.

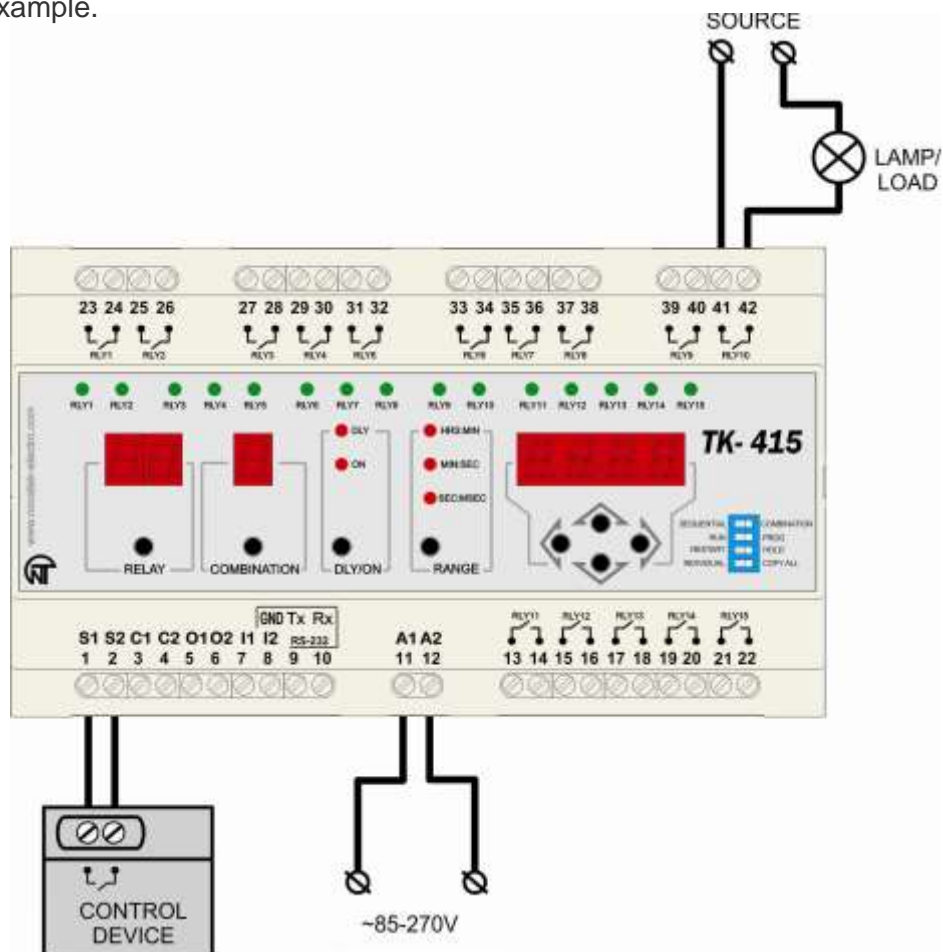

Figure 2.1 - Typical method of timer connection

The Figure 2.2 represents the method of cascade connection of three timers. Please, pay attention that inputs C1 and C2 are shorted.

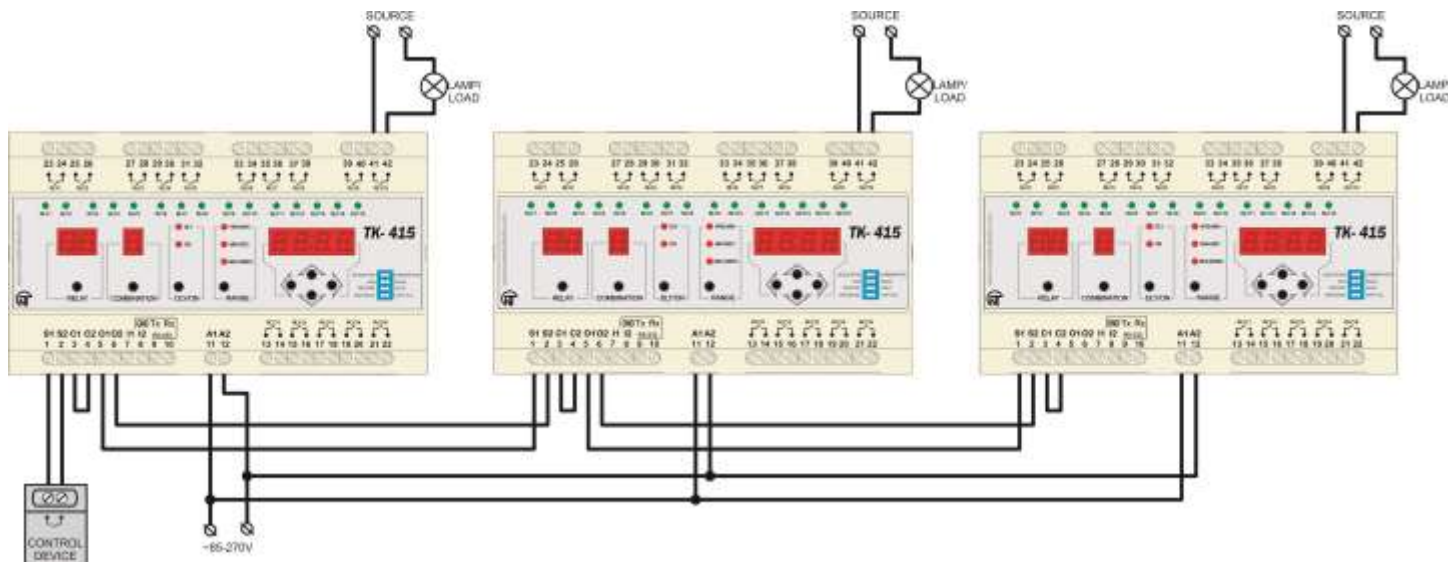

Figure 2.2 - Cascade connection of timers

Method of cascade connection of timers with possibility of cycle work (upon completion of operation of last timer the first one starts operating) is represented at Figure 2.3:

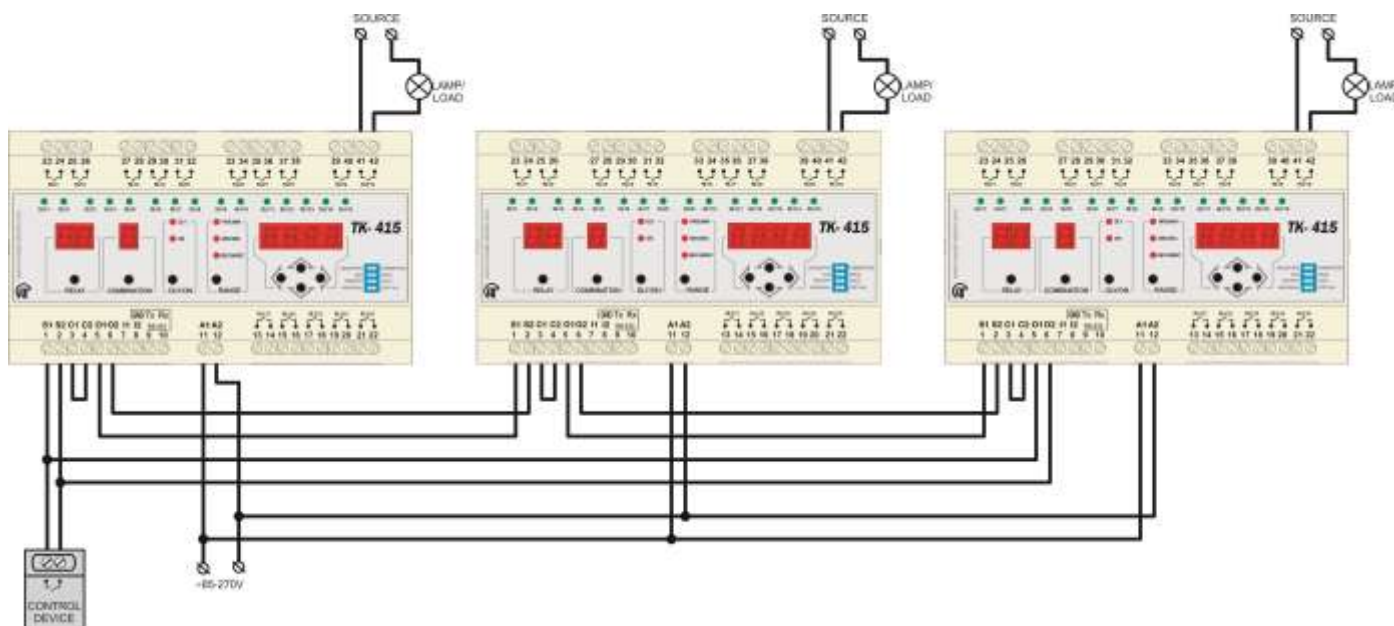

Figure 2.3 - Cycle operation of timers in case of cascade connection

## 2.2 SAFETY MEASURES

2.2.1 **ATTENTION!** Connection of inputs S1/S2, C1/C2, I1/I2, to external power sources may cause failure of device. These inputs should be connected only to insulated contacts of relay or switches.

2.2.2 Power plug-in load must not exceed specified herein as this can cause overheating of the contact group and fire products.

2.2.3 In the TK-415 uses a life-threatening stress. When troubleshooting, maintenance, assembly work, you must disable the device and attached actuators on the network.

2.2.4 It is not intended for use in bumps and knocks.

2.2.4 Not allowed ingress of moisture to the input terminals terminal blocks and internal element device.

2.2.5 Do not use the device in harsh environments with content in the atmosphere, acids, alkalis, oils, etc.

2.2.6 Connection, adjustment and maintenance of the unit must be performed only by qualified specialists, having learned this operation manual.

## 2.3 TIMER PROGRAMMING

### 2.3.1 Sequential timer programming

1. Fix switch RUN/PROG in position PROG.
2. For sequential timer selection fix switch SEQ/COMB in position SEQ. Supply power to inputs A1 and A2.
3. Using the button RELAY select the channel 1.
4. Using the button DLY/ON select time DLY for time setting, during which the contacts of channel relay will be open.
5. Press RANGE for selection of necessary time range.
6. Using arrow buttons set the necessary time.
7. Repeat steps 4 through 6 for status time setting ON, during which the contacts of channel relay will be closed.
8. Repeat steps 3 through 7 for setting of other channels.

### 2.3.2 Combination timer programming

1. Fix switch RUN/PROG in position «PROG».
2. For selection of combination timer fix switch SEQ/COMB in position COMB. Energize the inputs A1 and A2.
3. Using button RELAY select channel 1.
4. Using button COMBINATION select combination 1.
5. Using button DLY/ON select time DLY for time setting, during which the contacts of channel relay will be open.
6. Press RANGE for selection of necessary time range.
7. Using arrow buttons set the necessary time.
8. Repeat steps 5 through 7 for set of status ON, during which contacts of channel relay will be closed.
9. Repeat steps 4 through 8 for setting the other channel combinations.
10. Repeat steps 3 through 9 for setting of other channels and their combinations.

## 2.4 TIMER START

1. Fix the switch RUN/PROG in position RUN. Energize inputs A1 and A2.
2. Closure of contacts S1 and S2 on the front panel for at least 150 milliseconds causes execution of set program by the timer.
3. Execution of program is started from the first channel (first combination) and position of contacts OFF.
4. Contacts S1 and S2 may be permanently closed from start of program after power supply.

## 2.5 RESETTING

For resetting to default settings (zero) it is necessary in program mode switch SEQ/COMB in opposite position.

## 2.6 SETTINGS COPYING

If the switch INDIVID/COPY ALL is in position COPY ALL under mode RUN causes copying settings of the first channel in settings of other channels. In position INDIVID time of each channel and combination requires individual setting.

## 2.7 PAUSE

Zero potential between inputs I1 and I2 causes stop of countdown of current time of active channel till the moment when the closure between these inputs will be removed.

## 2.8 CYCLE OPERATION OF TIMER

For timer cycle operation (see Diagram 1.2) it is required that inputs C1 and C2 should be open. Otherwise, the program will be executed only once (see Diagram 1.1).

## 2.9 JOINT OPERATION OF SEVERAL TIMERS IN SEQUENTIAL MODE

In case of cascade connection of several timers, outputs O1 and O2 of the first timer should be connected to inputs S1 and S2 of the second timer, respectively etc., and inputs C1 and C2 should be short-circuited

between each other. For cycle operation of all timers in case of cascade connection it is necessary to connect outputs O1 and O2 of last timer to connect to the inputs S1 and S2 of the first one.

### **3 TERMS OF SERVICE AND STORAGE, MANUFACTURER'S WARRANTY**

3.1 The service life of TK-415 is 10 years. After the service life is over, one should contact the manufacturer.

3.2 The manufacturer guarantees the failure-free operation of TK-415 within 36 months since the day of purchase.

3.3 During the warranty period the manufacturer produces a free repair of the product in compliance with customer requirements specifications, rules governing the storage, installation and operation. The product is not eligible for warranty service in the following cases:

- Completion of warranty period or period of service;
- The product shows signs of physical damage (cracks, chips, cuts, deformation, etc.) could be caused by high or low temperature, mechanical stress, fractures, falls, etc.
- The presence of traces of moisture, foreign objects, dust and dirt inside the unit (including insects), exceeding the permissible limits specified in the passport.
- Repair of products does the organization or person that does not have appropriate authorization from the manufacturer.
- Complete the product does not meet the "Operating Manual" (no sensor changes the electrical circuit, change denominations of components);
- Damage caused by an electric current or voltage values which exceed the nameplate, improper or careless handling of the product is not subject to the instructions for installation and use;
- A lightning strike, fire, flooding, lack of ventilation and other causes beyond the control of the manufacturer.

3.4 Warranty and after-sales service (at current rates) is the place of purchase;

3.5 Manufacturer's warranty does not guarantee reimbursement of direct or indirect damages, loss or damage, as well as costs associated with transporting the product to the service centre.